

A multi-functional sliding bed trailer suitable for carrying a wide variety of loads. Suitable applications include transportation of wheeled and tracked plant, forklifts, access platforms, coach and vehicle recovery, ISO containers and general haulage.



THE 'OLDBURY SLIDER'



MOD 1983 model, still in service today.

"A wonderfully, flexible trailer acting as a semi low loader, a flat and a container carrier. A great work-horse for over 20 years."

RAF Stafford.

MOD 2003 model, 26 tonne payload. Ideal for plant movement.

■ Features

- 3 off ROR Axles
10 tonne drum-braked axles (Discs optional)
- Air Suspension
- ISO swing clearances
- Integral Rear Lighting
Rear lighting integrated in rear ramps
- Mechanical Sliding Bogie c/w locking mechanism
Simple pneumatically operated locks
- Electrical winch (Optional)
- 12 pairs of rope hooks
- 6 pairs of lashing rings in rave
- 1 pair of interlinked 2 speed landing legs
- Haldex 2S/1M ABS braking system



Ideal for vehicle recovery.

THE 'OLDBURY SLIDER'

■ Advantages

- No step frame allowing full utilisation of bed
- Ideal plant / vehicle recovery trailer
- Carries 10, 20, 30, 40 and 45ft ISO containers
- Ramps light enough for one man operation – no need for hydraulics
- Rear loading ramps are small, reducing drag and fuel consumption
- Simple one man operation of bogie locking mechanism
- No hydraulics offering low maintenance costs

SPECIFICATIONS

Payload	26 tonnes (approx)
Deck Heights	1510mm to 1140mm (with 1300 kingpin height)
Kingpin to rear end	12000mm (ramps in upright position.)
O/A length	13510mm
Width	2550mm
Loading Angle	10 degrees (can be lower with additional ramps)

'SLIDER' DESIGN WEIGHTS

	TRI-AXLE	TANDEM AXLE
Kingpin	10,500 kgs	10,500 kgs
Bogie	24,000 kgs	18,000 kgs
ULW (approx)	9,000 kgs	8,250 kgs
Payload C&U (approx)	26,000 kgs	21,250 kgs
Gross Trailer Weight	34,500 kgs	28,500 kgs

Travelling condition

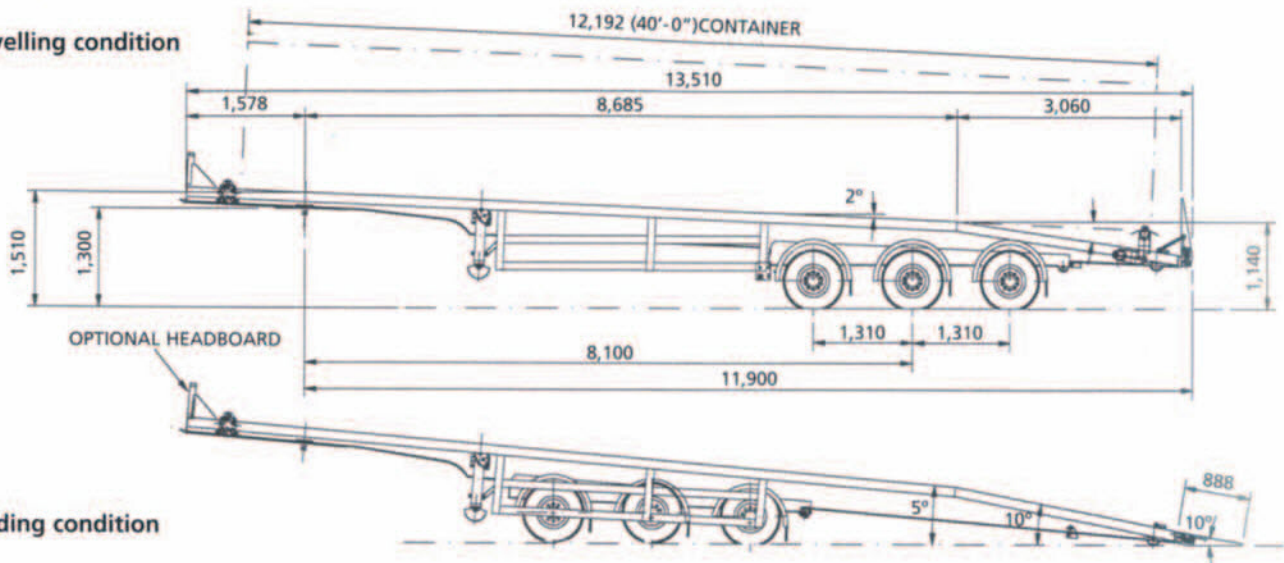

Loading condition

■ Options

- Brakes and lights to meet ADR regulations
- Spare wheel carrier
- Toolboxes
- Adjustable or fixed headboard
- Twistlocks for 10ft, 20ft, 30ft and 40ft ISO containers
- D shackles in bed or on rave
- Also available in tandem axle form



Email: sales@oldburyuk.co.uk
www.oldburyuk.co.uk